

THIS DRAWING IS UNPUBLISHED. RELEASED FOR PUBLICATION
 © COPYRIGHT - BY TYCO ELECTRONICS CORPORATION. ALL RIGHTS RESERVED.

LOC		DIST		REVISIONS			
P	LTR	DESCRIPTION		DATE	DWN	APVD	
	A	REVISED PER ECO-07-004004		12/13/07	SS	MM	

- ① Be Cu PER TE SPEC 100-45, HEAT TREAT PER 111-45-1.
- ② STEEL PER TE SPEC 100-213, HEAT TREAT PER 111-213-6.
- ③ PLATE .000300 MIN THK CADMIUM PLATE PER 112-3-3 WITH SUPPLEMENTAL IRIDITE CHROMATE COATING.
- 4. ALL DIMENSIONS SHOWN ARE WITH COMPONENTS IN PLACE AND CLIP SECURELY MOUNTED TO CHASSIS.

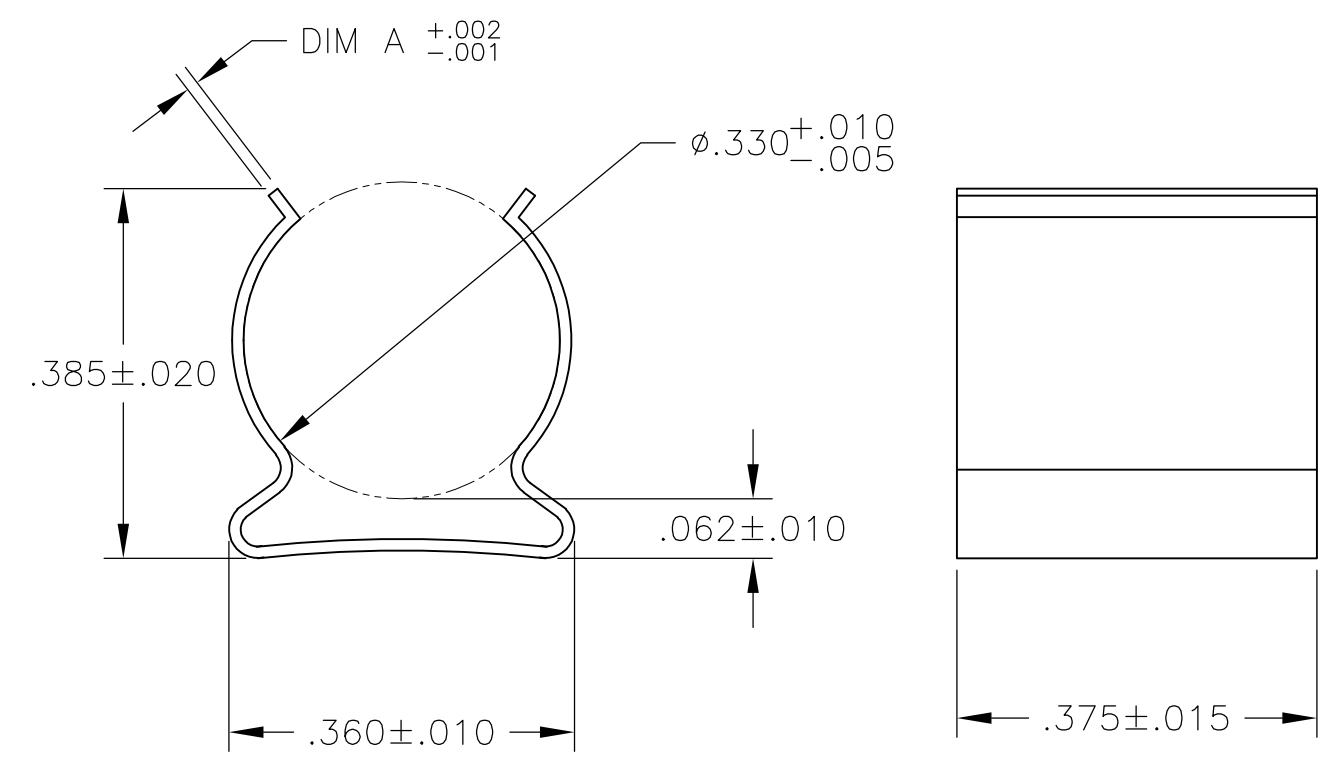
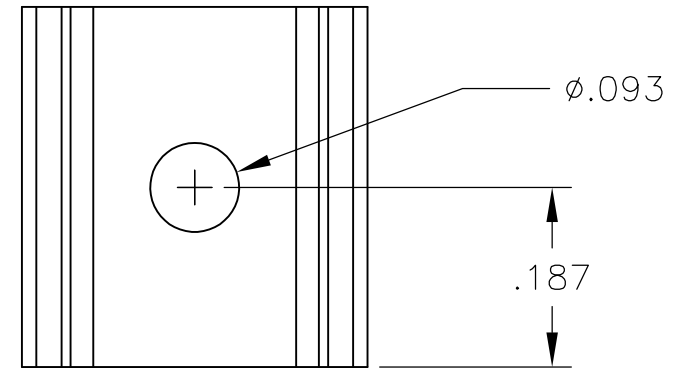

OBSELETE	NOTES	DIM A	AUGAT NUMBER	PART NUMBER
	①③	.010	6005-6CC	1571685-1
	②③	.012	6005-6A	4-1437499-4

THIS DRAWING IS A CONTROLLED DOCUMENT.		DWN M.BINNER 21APR04	Tyco Electronics Corporation Harrisburg, PA 17105-3608		
DIMENSIONS: INCHES		CHK K.WRIGHT 21APR04	NAME CLIP		
TOLERANCES UNLESS OTHERWISE SPECIFIED:		APVD K.WRIGHT 21APR04	PRODUCT SPEC -		
0 PLC ± - 1 PLC ± - 2 PLC ± - 3 PLC ± .005 4 PLC ± - ANGLES ± 1°		APPLICATION SPEC -	SIZE A3	CAGE CODE 00779	DRAWING NO G-4-1437499-4
MATERIAL -		FINISH -	WEIGHT -	RESTRICTED TO -	
CUSTOMER DRAWING			SCALE 1:1	SHEET 1 OF 1	REV A